

## Zener Diodes

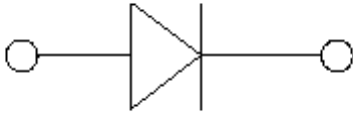

### Features

- Moisture sensitivity level 1
- Zener voltage 2.4V~47V

### Application

- Linear voltage regulator
- DC regulator
- Small-signal surge protection

### Mechanical data

- **Package:** SOD-323
- **Terminals:** Tin plated leads, solderable per J-STD-002 and JESD22-B102

PARAMETER	SYMBOL	UNIT	VALUE
Power Dissipation*(note)	$P_D$	mW	400
Storage Temperature Range	$T_{stg}$	°C	-55~+150
Junction Temperature	$T_J$	°C	-55~+150
Maximum Forward Voltage @ $I_F=10mA$	$V_F$	V	0.9
Maximum Regulator Current	$I_{ZM}$	mA	$P_D / V_z$
Thermal Resistance Junction to Ambient Air*(note)	$R_{\theta JA}$	°C /W	312

\*Note: Device mounted on PCB

### Ordering Information (Example)

PREFERRED P/N	PACKING CODE	UNIT WEIGHT(g)	MINIMUM PACKAGE(pcs)	INNER BOX QUANTITY(pcs)	OUTER CARTON QUANTITY(pcs)	DELIVERY MODE
BZT52B2V4BS THRU BZT52B47BS	F2	Approximate 0.0048	3000	30000	120000	7" reel

### Electrical Characteristics ( $T_A=25^\circ C$ Unless otherwise specified )

Type Number	Device Marking	$V_z$ at $I_Z T$ (V)			$Z_{zT}(\Omega)$		$Z_{zk}(\Omega)$		$I_R(\mu A)@V_R$		Typical Temperature Coefficient @ IZTC $mV/^\circ C$		Diode capacitance Cd (pF)	Non-repetitive peak reverse current $I_{zsm}$ (A)
		min.	typ.	max.	$I_{ZT}(mA)$	max.	$I_{zk}(mA)$	max.	max	$V_R(V)$	Min	Max	max	max
BZT52B2V4BS	B0Z	2.34	2.4	2.46	5	100	1	564	45	1	-3.5	0	450	6
BZT52B2V7BS	B1Z	2.63	2.7	2.77	5	100	1	564	20	1	-3.5	0	450	6
BZT52B3V0BS	B2Z	2.94	3	3.06	5	89	1	564	9	1	-3.5	0	450	6



# BZT52B2V4BS THRU BZT52B47BS

BZT52B3V3BS	B3Z	3.23	3.3	3.37	5	89	1	564	4.5	1	-3.5	0	450	6
BZT52B3V6BS	B4Z	3.53	3.6	3.67	5	84	1	564	4.5	1	-3.5	0	450	4.5
BZT52B3V9BS	B5Z	3.82	3.9	3.98	5	84	1	564	2.7	1	-3.5	0	450	4.5
BZT52B4V3BS	B6Z	4.21	4.3	4.39	5	84	1	564	2.7	1	-3.5	0	450	3.5
BZT52B4V7BS	B7Z	4.61	4.7	4.79	5	75	1	564	2.7	2	-3.5	0.2	300	3.5
BZT52B5V1BS	B8Z	5	5.1	5.2	5	60	1	480	2	2	-2.7	1.2	300	3
BZT52B5V6BS	B9Z	5.49	5.6	5.71	5	40	1	400	1	2	-2	2.5	200	3
BZT52B6V2BS	BAZ	6.08	6.2	6.32	5	10	1	150	3	4	0.4	3.7	200	3
BZT52B6V8BS	BBZ	6.66	6.8	6.94	5	15	1	141	2	4	1.2	4.5	200	2
BZT52B7V5BS	BCZ	7.35	7.5	7.65	5	15	1	80	1	5	2.5	5.3	150	2
BZT52B8V2BS	BDZ	8.04	8.2	8.36	5	15	1	80	0.7	5	3.2	6.2	150	2
BZT52B9V1BS	BEZ	8.92	9.1	9.28	5	15	1	100	0.5	6	3.8	7	150	1.8
BZT52B10BS	BFZ	9.8	10	10.2	5	20	1	150	0.2	7	4.5	8	90	1.8
BZT52B11BS	BGZ	10.78	11	11.22	5	20	1	150	0.1	8	5.4	9	85	1.8
BZT52B12BS	BHZ	11.76	12	12.24	5	25	1	150	0.1	8	6	10	85	1.8
BZT52B13BS	BJZ	12.74	13	13.26	5	30	1	170	0.1	8	7	11	80	1
BZT52B15BS	BKZ	14.7	15	15.3	5	30	1	200	0.1	10.5	9.2	13	75	1
BZT52B16BS	BLZ	15.68	16	16.32	5	40	1	200	0.1	11.2	10.4	14	75	1
BZT52B18BS	BMZ	17.64	18	18.36	5	45	1	225	0.1	12.6	12.4	16	70	1
BZT52B20BS	BNZ	19.6	20	20.4	5	55	1	225	0.1	14	14.4	18	60	1
BZT52B22BS	BPZ	21.56	22	22.44	5	51	1	235	0.045	15.4	16.4	20	60	0.6
BZT52B24BS	BRZ	23.52	24	24.48	5	65	1	235	0.045	16.8	18.4	22	55	0.6
BZT52B27BS	BSZ	26.46	27	27.54	5	75	0.5	282	0.045	18.9	21.4	25.3	50	0.6
BZT52B30BS	BTZ	29.4	30	30.6	5	75	0.5	282	0.045	21	24.4	29.4	50	0.6
BZT52B33BS	BUZ	32.34	33	33.7	5	80	1	325	0.1	25	27.4	33.4	45	0.6
BZT52B36BS	BVZ	35.28	36	36.72	5	84	0.5	329	0.045	25.2	30.4	37.4	45	0.6
BZT52B39BS	BWZ	38.22	39	39.78	5	122	0.5	329	0.045	27.3	33.4	41.2	45	0.6
BZT52B43BS	BXZ	42.14	43	43.86	5	141	0.5	353	0.045	30.1	37.6	46.6	40	0.6
BZT52B47BS	BYZ	46.06	47	48.94	5	160	0.5	353	0.045	33	42	51.8	40	0.5



# BZT52B2V4BS THRU BZT52B47BS

## ■ Characteristics (Typical)

Fig 1:  $P_D$ - $T_a$  Curve

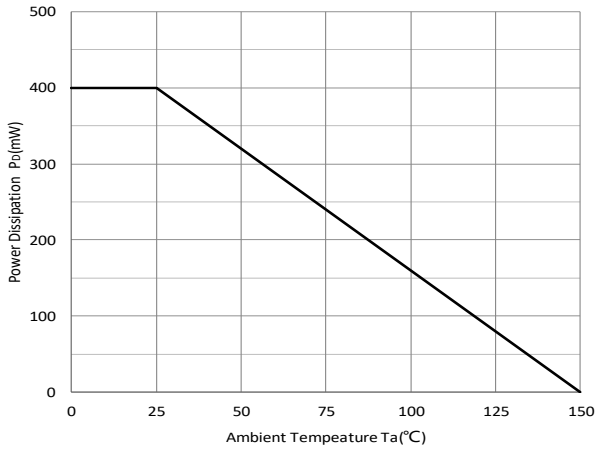

Fig 2: Zener Breakdown Characteristics

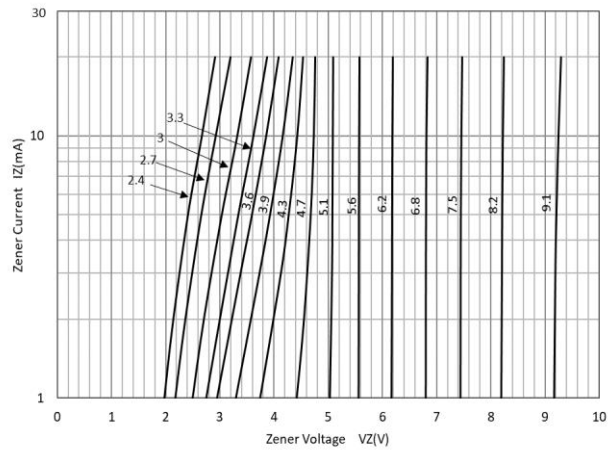

Fig 3: Zener Breakdown Characteristics

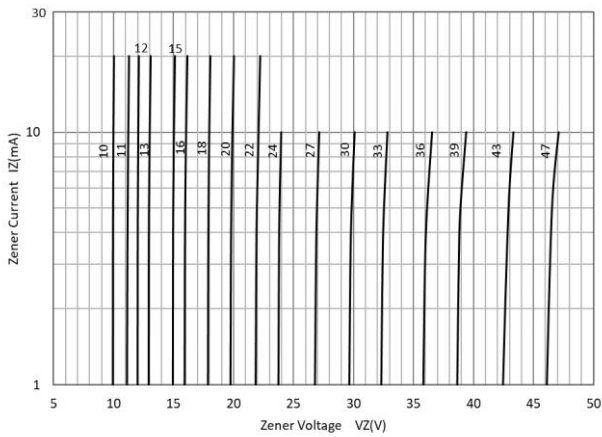

Fig 4: Typical Temperature Coefficient

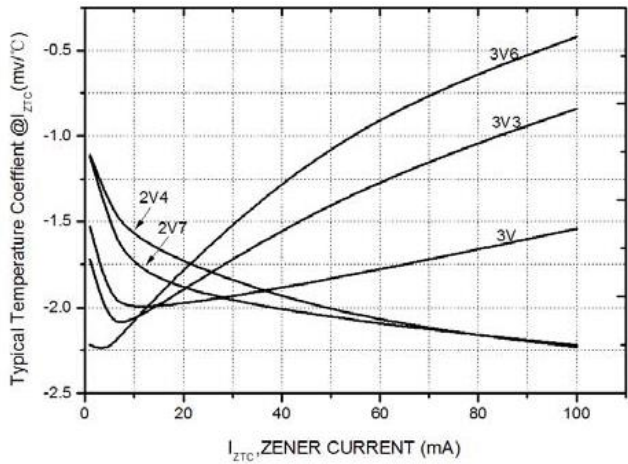

Fig 5: Typical Temperature Coefficient

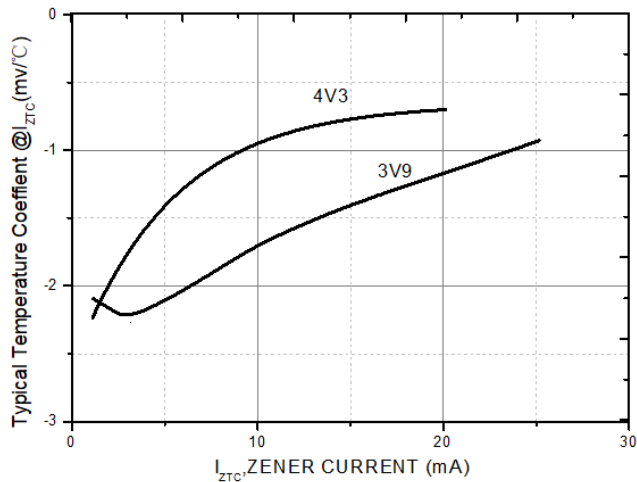
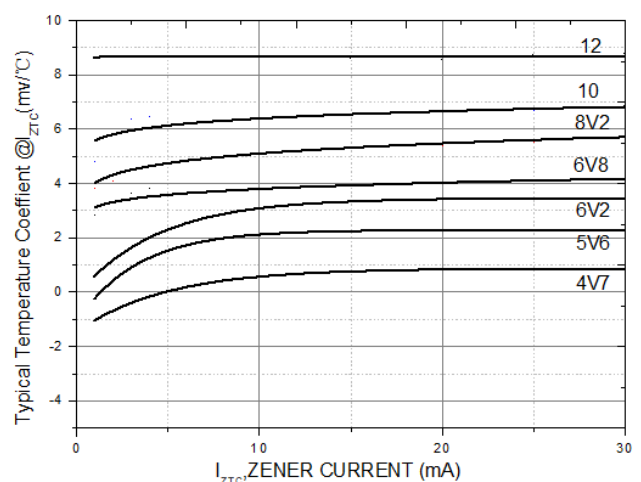

Fig 6: Typical Temperature Coefficient





# BZT52B2V4BS THRU BZT52B47BS

Fig 7: Typical Temperature Coefficient

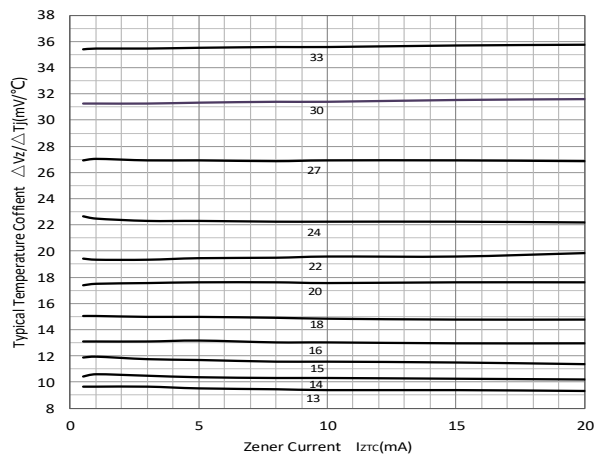

Fig 8: Typical Temperature Coefficient

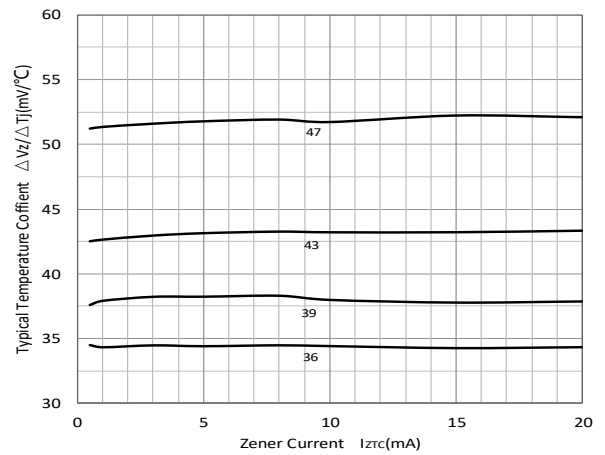

Fig 9: Typical Forward Voltage

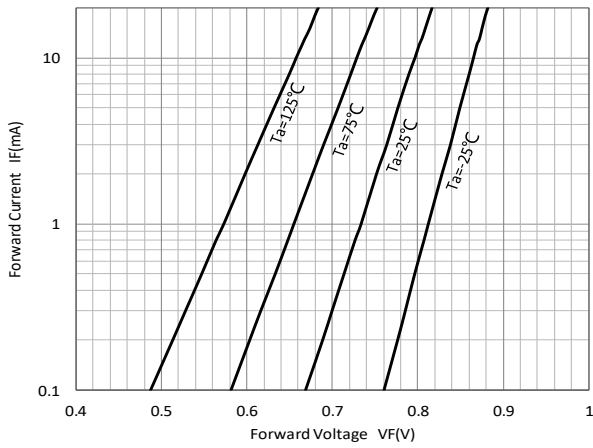

Fig 10: Typical Reverse Current

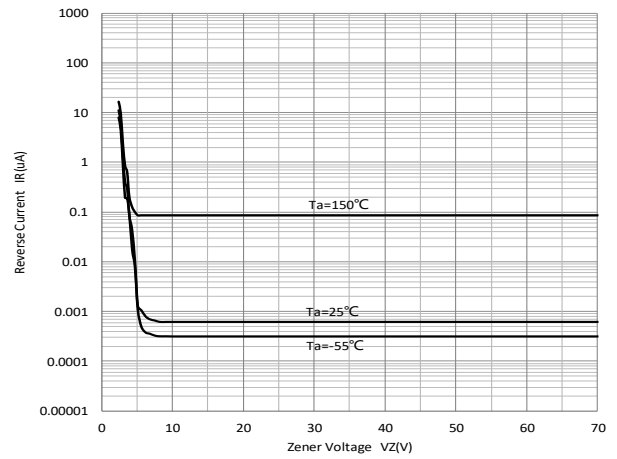
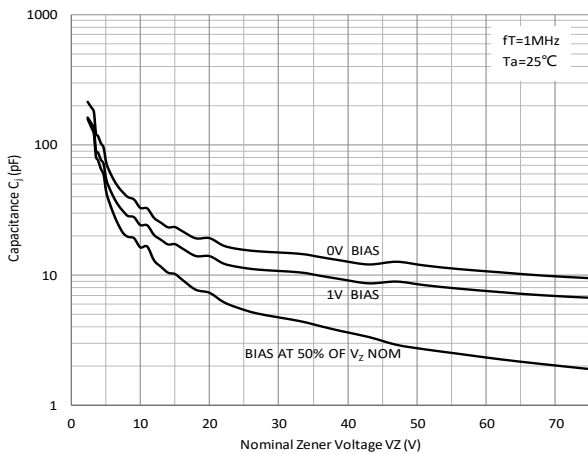

Fig 11: Typical Capacitance





# BZT52B2V4BS THRU BZT52B47BS

## ■Outline Dimensions

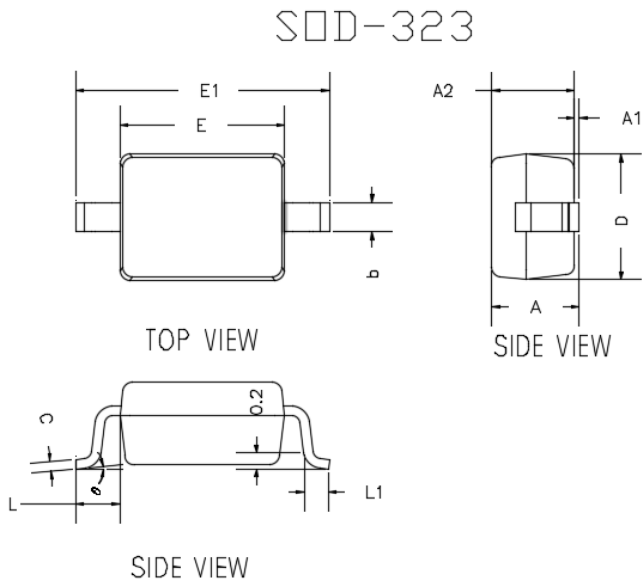

DIMENSIONS				
DIM	INCHES		MM	
	MIN	MAX	MIN	MAX
A	---	0.0393	---	1.0000
A1	0.0000	0.0039	0.0000	0.1000
A2	0.0314	0.0354	0.8000	0.9000
b	0.0098	0.0157	0.2500	0.4000
c	0.0031	0.0059	0.0800	0.1500
D	0.0472	0.0551	1.2000	1.4000
E	0.0629	0.0709	1.6000	1.8000
E1	0.0984	0.1063	2.5000	2.7000
L	0.0187TYP		0.475TYP	
L1	0.0098	0.0157	0.250	0.400
e	0°	8°	0°	8°

## ■Soldering Footprint

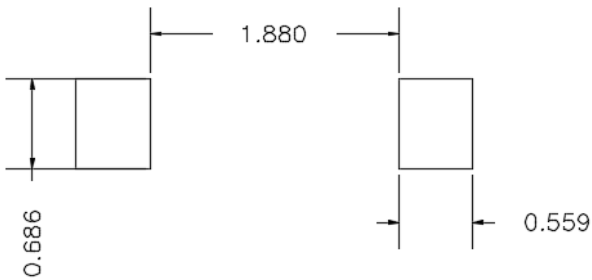

UNIT : mm

SUGGESTED SOLDER PAD LAYOUT



## BZT52B2V4BS THRU BZT52B47BS

---

### Disclaimer

The information presented in this document is for reference only. Yangzhou Yangjie Electronic Technology Co., Ltd. reserves the right to make changes without notice for the specification of the products displayed herein to improve reliability, function or design or otherwise.

The product listed herein is designed to be used with ordinary electronic equipment or devices, and not designed to be used with equipment or devices which require high level of reliability and the malfunction of which would directly endanger human life (such as medical instruments, transportation equipment, aerospace machinery, nuclear-reactor controllers, fuel controllers and other safety devices), Yangjie or anyone on its behalf, assumes no responsibility or liability for any damages resulting from such improper use of sale.

This publication supersedes & replaces all information previously supplied. For additional information, please visit our website [http:// www.21yangjie.com](http://www.21yangjie.com) , or consult your nearest Yangjie's sales office for further assistance.